

**ZENITH00**

**High speed, large volume CNC CMM**

Large measurement CNC CMM's are now affordable

# High Speed, Large measurement CNC CMM

## Innovative metrology

There are a number of philosophies that Aberlink have adopted since it was founded in 1993 that have revolutionised the way that modern CMM's are now manufactured. Firstly the structure of the machine is fabricated entirely from aluminium alloy. This has a number of advantages: the cost of machining is significantly lower than for machines made from granite, ceramic or other exotic materials. The aluminium is stress relieved to produce a highly stable structure and, with modern computing power, running a real-time error map to achieve high accuracy is simple.

Also as the machine is made from a single material it will expand and contract uniformly with temperature change and hence Aberlink offer easy-to-use temperature compensation within the user software. If machines were made from different materials, a change in temperature would cause a distortion and hence introduce errors.

All moving parts are light and this, combined with good design, means that the machines have low inertia and therefore optimal acceleration characteristics. Hence the machines are really fast, minimising inspection times.

As Aberlink performs all the manufacturing in-house, the design of the machine has been produced based around the ease of manufacture. This has created an elegant design which is the epitome of simplicity - and the knock on of a simple design is reliability.

Aberlink's philosophy of producing everything in-house, including the revolutionary Aberlink 3D user software, means that we are not only able to keep control of all aspects of the business but also overheads are kept to a minimum and this is reflected in the amazing prices at which we are able to sell our high quality CMM's.

### Air Bearings

Air bearings of optimised stiffness are employed on all axes. Friction free bearings mean that axes never wear.



### All Aluminium Construction

Industry standard, all aluminium construction results in low inertia and low thermal mass, ideal for use in less than perfect environments.



### Granite Surface Table

The granite surface table is available in a range of sizes and allows us to offer up to 3m of Y axis travel utilising a common 1m bridge.



### Compact Design

The Zenith too offers an extremely large measurement volume relative to it's overall dimensions. The 600mm Z axis variant requires a ceiling height of just 2.6m.



The **Zenith** too: large measurement CMM's are now affordable

Zenith too ..... the advantages are clear

## Measurement Volume Options

X-axis 1000mm  
Y-axis 1000, 1500, 2000, 2500 or 3000mm  
Z-axis 600 or 800mm

## Reliability

The robust design of the Zenith too has been developed for use on the shop floor, and is based on the proven record of the original Zenith.

## All Aluminium Bridge

Industry standard, all aluminium construction results in low inertia and low thermal mass, ideal for use in less than perfect environments.

## Ultra High-Speed

Low inertia and leading edge drive design vastly reduces inspection times.

## Accuracy

Very high measurement accuracy is achieved through the latest metrology and manufacturing methods.

## Complete Metrology Package

Aberlink supplies a complete 'Turn-Key' package including computer, software, probe and training.

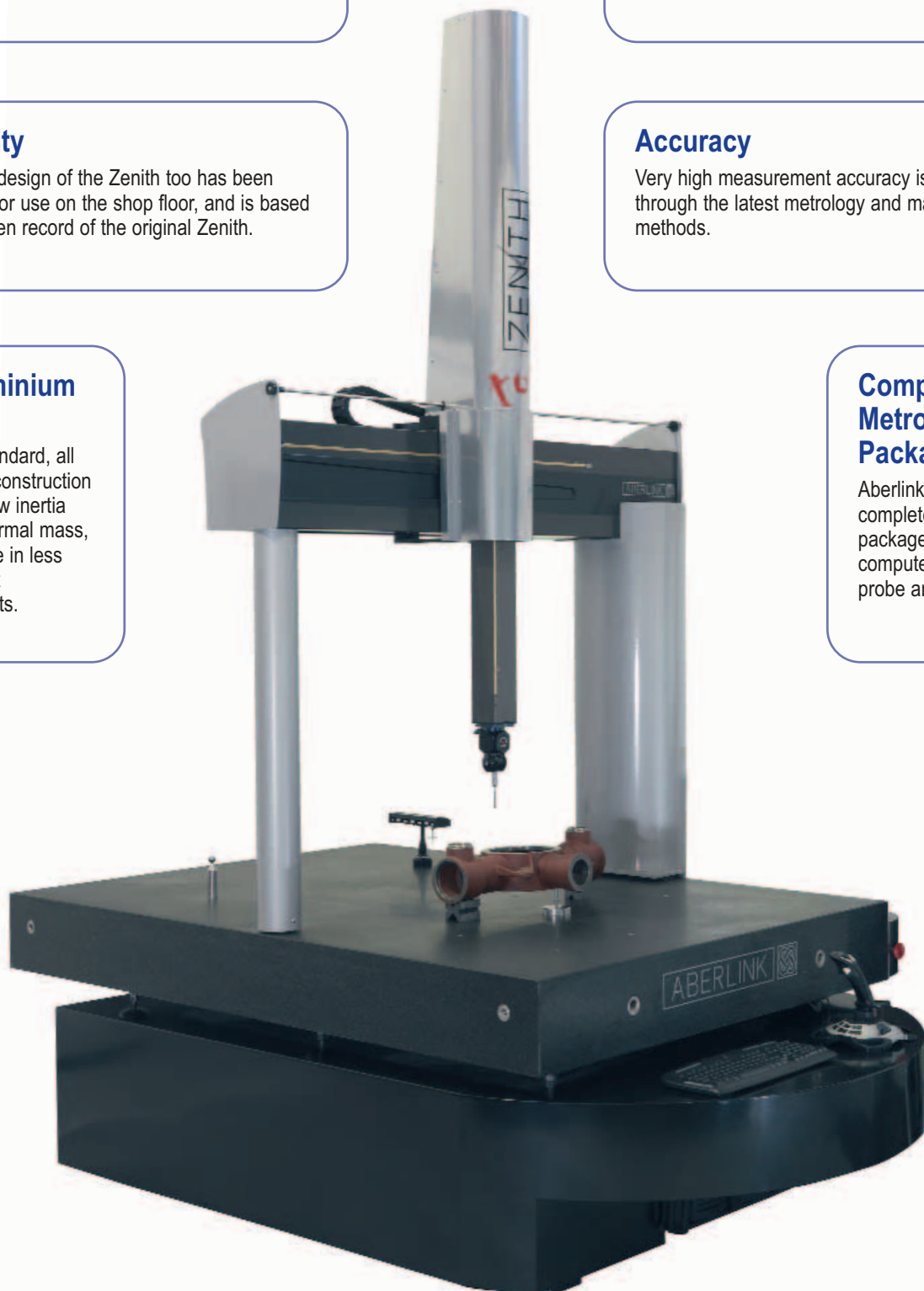

# Aberlink 3D Software

## Aberlink 3D ..... making 3D measurement as easy as it can be

Aberlink 3D Software is the very latest geometric measurement software designed around a graphical interface, not just with graphics added on. Aberlink 3D can be used either on manual or CNC machines, can be configured for use in either 2-dimensions or 3-dimensions and is equally at home when used with either probing systems or vision.

The user software is revolutionary, as it builds up a picture of the component being inspected on the computer screen. Dimensions can be 'picked off' the picture in a way that corresponds directly to the way the component has been dimensioned on the drawing.

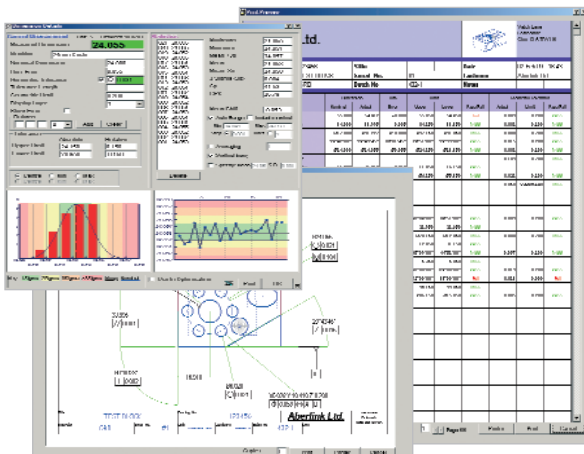
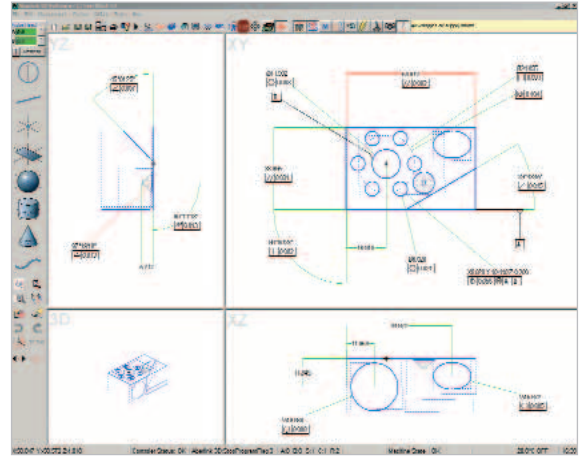

Inspection reports can be in the form of fully dimensioned graphical representations as created on the screen, or tabulated reports in various formats that can show nominals, tolerances, errors, pass/fails, geometric tolerances etc. These reports can also be output to an Excel spreadsheet.

Further reports are available to show the form of features (roundness, straightness etc.), hole or point positions, or complete batch results on one report.

The User's company name also appears on all output.

Every time a component is inspected, a program for measuring subsequent components is automatically created. The software automatically calculates 'safe' moves between features, even when the probe is indexing – just another thing that the operator doesn't have to worry about!

Aberlink 3D software is not only way ahead of it's competition in being the industry standard for 'Easy to Use' software, but also has the depth of functionality to make it the choice for either occasional users or full time inspection professionals.

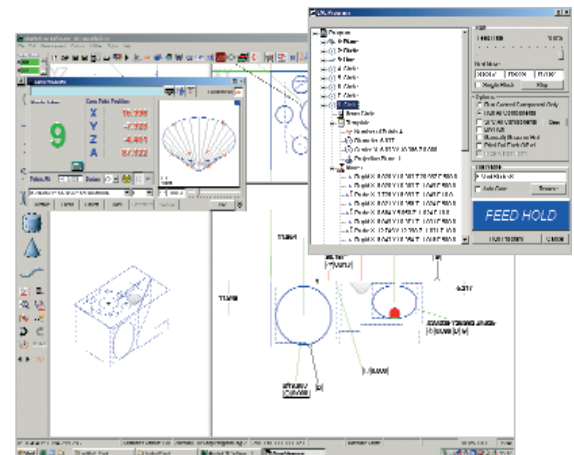

# Aberlink CAD Comparison Module

..... sometimes measuring against a CAD model is the only solution

Aberlink 3D geometric measurement software has become the industry standard, easy-to-use software when geometric features need to be measured against a drawing. However, sometimes components also contain complex surfaces, or may be conventional drawings for a component simply don't exist. In this situation the only way to inspect a part may be against it's CAD model.

Aberlink's CAD comparison module allows users of the Aberlink 3D software to import a solid model from CAD in either a STEP or an IGES format, and then take measurements using the CAD model as master data. This can be done on either a manual CMM or in full CNC mode.

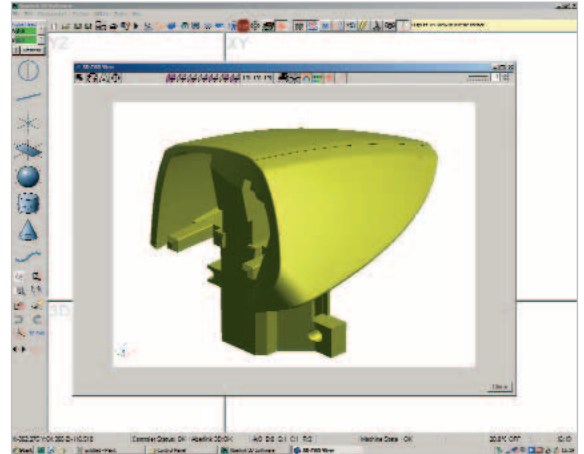

The solid model appears in an additional floating window on top of the main Aberlink 3D screen.

Alignment of the part to the CAD model can be done in a number of ways using either geometric features, or by best-fitting through measured points on the component's surface, or by a combination of both methods.

Any points taken in a measured feature will now appear in the CAD window. These points will be displayed as a colour-coded dot on the model, and can either have a line leading to a box showing the error of the measured point, or alternatively the length of the attached line can be proportional to the error. In this way it is easy to visualise the distortion of a surface relative to the theoretical model.

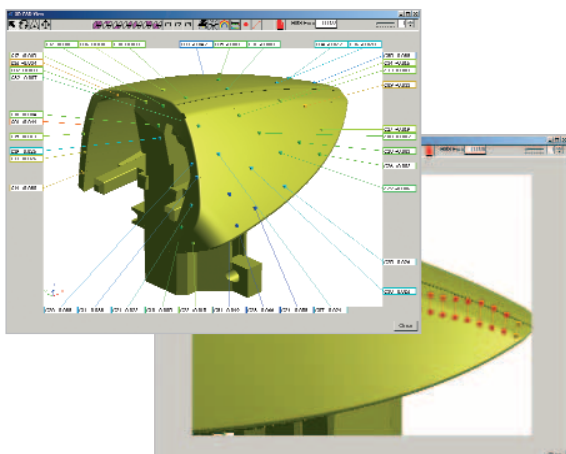

The best-fit function allows full 3D re-alignment of the model in order to minimise the RMS errors of any set of measured points within a curve unit.

Reports can be prepared at the click of a mouse button and can be either graphical, in a tabulated format, or printed as a combination of both. Reports can be built up from multiple features or multiple inspections, which can be printed from within the Aberlink software or alternatively exported as an Excel file.

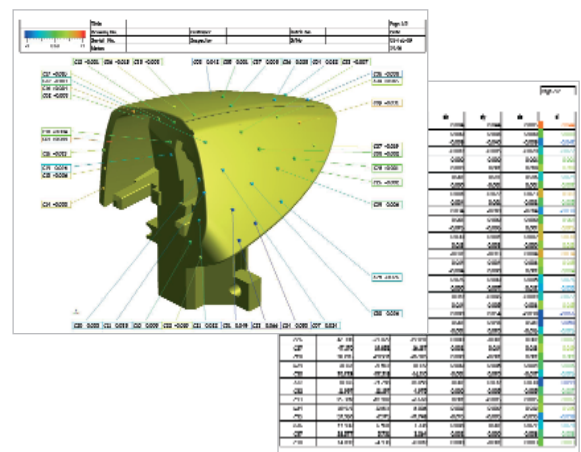

# Aberlink Camera System

## Non-contact measuring on a CMM

Aberlink's Camera System offers a non-contact facility on any Aberlink CMM. A clever design of magnetic, kinematic joint allows the probe and camera to be swapped in just seconds. This means that components can be inspected using both touch trigger and vision inspection technology within the same measurement program.

The camera incorporates a telecentric lens, which gives distortion-free images on the monitor. The lens has a manual adjustment that will permit working focal lengths up to 400mm, with a field of view up to 35mm.

Full automatic edge detection tools are available within the Aberlink 3D measurement software, which allow the camera to be used either in manual or CNC mode – please see opposite for a description of the vision software available from Aberlink.



The camera also incorporates a fully programmable 16 LED light ring, which contains alternate white and UV LEDs. The white LEDs provide surface illumination, in the normal manner, whilst the UV LEDs provide an ingenious solution to the perennial problem of backlighting on a CMM: The component to be measured is placed on a plate containing a special reflective paper.

When illuminated with UV light, any light striking the surface of the component is reflected and because it is UV, it is invisible to the camera. However, any light which passes by the component and strikes the reflective paper fluoresces and therefore becomes visible. The effect of this is that an extremely sharp silhouette of the component is produced because it has now been lit from underneath.

This ingenious new invention not only negates the need for the previously used cumbersome light boxes, but also provides a fully controllable backlight source, which can easily be used over the whole bed of a CMM. The fact that it is controllable in software is especially useful on CNC machines, when the user will often need to automatically switch between top and backlighting on a single component.

Just another example of Aberlink's innovative approach to solving metrology problems!

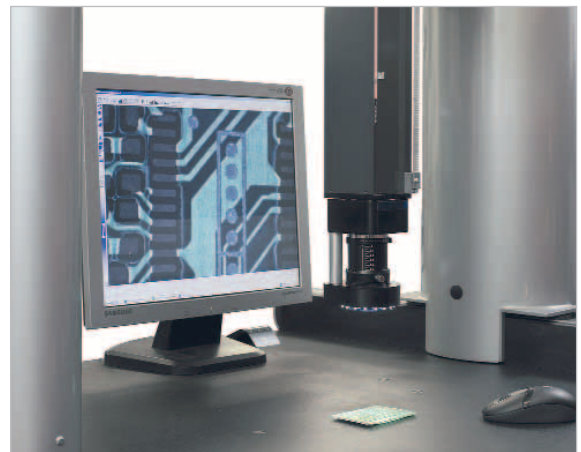

# Aberlink Vision Software

## Powerful vision tools ..... yet so easy to use

Aberlink's Vision Module allows the Aberlink 3D measurement software to be used not only on touch-trigger CMMs, but also with a camera system, to provide non-contact measurement under either manual or fully automatic CNC control.

The camera icon will open an additional window showing the image of the camera. Measurements can then be performed using the camera image, including a full range of automatic edge detection tools, which will ensure fast and repeatable results without relying on the skill of the operator.

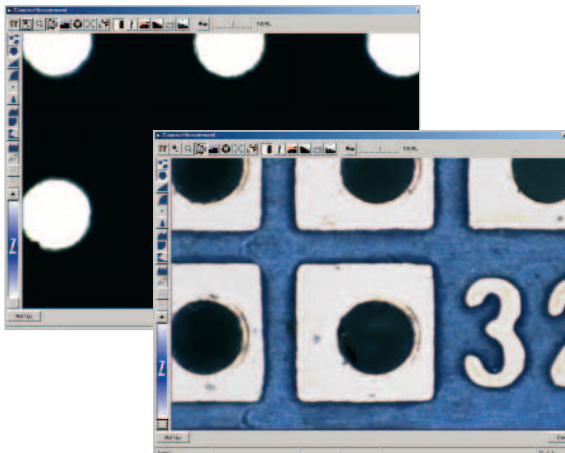
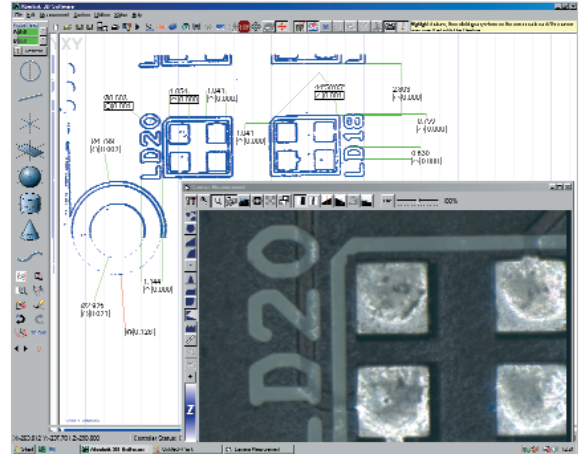

The lighting panel offers software control for surface illumination, back lighting and also TTL lighting, if available. The surface illumination tool allows directional control of the lighting as well as for intensity, which is fully automatic under CNC playback.

The curve tool also allows the software to trace around the profile of components. Dimensions can then either be called up directly on the measured data, or alternatively geometric features can be constructed through the points, or even a DXF file of the part can be imported and the data best-fitted to the file to view the actual measured shape.

Control of the Z axis and auto-focus is also available under software control.

Other standard measurement tools include lines, arcs, circles, points, peak points and automatic shape recognition. Measurements can be performed using edge detection, or centre line detection, or by using full cross-hairs or mouse cross-hairs, and there is also a unique Smart Measure function that will take discrete measurement points by detecting an edge in the vicinity of a mouse click.

Some special tools include the 'All Edge Points' function, where every edge within the field of view will be grabbed with just a single mouse click. There is a 'Thread Measure' tool for analysing thread forms, and a 'Screen Ruler' function for when you just need a quick measurement between two points on the image.

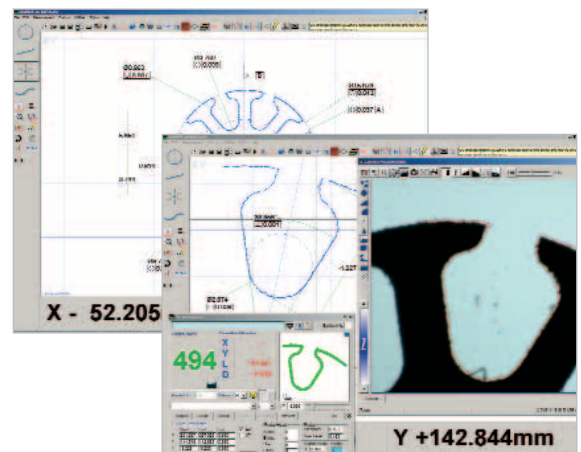

## For a successful company a ZENITH too is a necessity not a luxury

- Why have expensive CNC machines waiting to be set? Speed up feedback with a Zenith too.
- Why tie up skilled personnel carrying out slow traditional inspection?
- Why lose customers because you supplied out of tolerance parts?
- Attract more profitable work with a leading edge inspection centre.
- Some features can only be accurately inspected with a CMM.
- Intuitive software for the first time user means you are seeing the benefits fast.

## Inspection wastes thousands

Are you still using traditional methods of inspection, while expensive CNC machines are idle, or worse, your inspections are inaccurate or missed out completely?

Now at last with a Zenith too CMM, you can dramatically reduce inspection times and improve setting times throughout your business.

### Example:

Number of CNC machines	5
Time saved in inspection and setting (per machine, per shift)	0.5 hrs
Number of shifts per day	1
Daily time saving for inspection and setting	2.5 hrs
Hourly rate	£40
<b>Total annual inspection saving</b>	<b>£25,000</b>

Compare this with the price of a Zenith too and pay back will be in a matter of months! This means a massive improvement in your bottom line figure thereafter - and no expensive rejects, reworks or lost customers.

Specification	Zenith too 1000	Zenith too 1500	Zenith too 2000	Zenith too 2500	Zenith too 3000
Type	CNC	CNC	CNC	CNC	CNC
Measuring Volume	1000 x 1000 x 600 / 800	1000 x 1500 x 600 / 800	1000 x 2000 x 600 / 800	1000 x 2500 x 600 / 800	1000 x 3000 x 600 / 800
Table	solid granite	solid granite	solid granite	solid granite	solid granite
Accuracy	B89: 0.008/300mm VDI(U3): 0.0038 + L/250	B89: 0.008/300mm VDI(U3): 0.0038 + L/250	B89: 0.008/300mm VDI(U3): 0.0038 + L/250	B89: 0.008/300mm VDI(U3): 0.0038 + L/250	B89: 0.008/300mm VDI(U3): 0.0038 + L/250
Measuring System	Renishaw readheads and tape scale	Renishaw readheads and tape scale	Renishaw readheads and tape scale	Renishaw readheads and tape scale	Renishaw readheads and tape scale
Resolution	0.0005mm	0.0005mm	0.0005mm	0.0005mm	0.0005mm
Probe System	Full choice of Renishaw probes and probe heads	Full choice of Renishaw probes and probe heads	Full choice of Renishaw probes and probe heads	Full choice of Renishaw probes and probe heads	Full choice of Renishaw probes and probe heads
Max. Velocity Vector	500mm/sec	500mm/sec	500mm/sec	500mm/sec	500mm/sec
Max. Acceleration Vector	1000mm/s <sup>2</sup>	1000mm/s <sup>2</sup>	1000mm/s <sup>2</sup>	1000mm/s <sup>2</sup>	1000mm/s <sup>2</sup>
Bearings	Air bearings on all axes	Air bearings on all axes	Air bearings on all axes	Air bearings on all axes	Air bearings on all axes
Z Axis	Pneumatically counterbalanced	Pneumatically counterbalanced	Pneumatically counterbalanced	Pneumatically counterbalanced	Pneumatically counterbalanced
Max. Balance Weight	1 kg	1 kg	1 kg	1 kg	1 kg
Air Consumption	23 l/min (0.8 cfm) @ 4 bar	23 l/min (0.8 cfm) @ 4 bar	23 l/min (0.8 cfm) @ 4 bar	23 l/min (0.8 cfm) @ 4 bar	23 l/min (0.8 cfm) @ 4 bar
Required Air Pressure	4 bar (60 psi)	4 bar (60 psi)	4 bar (60 psi)	4 bar (60 psi)	4 bar (60 psi)
Software	Full graphical interface running on Windows	Full graphical interface running on Windows	Full graphical interface running on Windows	Full graphical interface running on Windows	Full graphical interface running on Windows

